

Impact Techniques for the Study of Physical Properties of Solids Under Shock-Wave Loading

R. A. GRAHAM

INTRODUCTION

Measurements of the characteristics of shock-waves in solids have been used for many years in the study of compressibilities under high pressure. In fact, shock-wave data are still the major source for compressibility data of solids above 100 kbar. There have been a number of review articles (1-6)² which describe the shock-wave compression experiments and results which are typical when high-explosive loading is used to produce the shock wave. Recently, however, new experimental apparatus and technique have been developed for performing shock-wave experiments in which the impact of flat-faced projectiles produces the shock waves. Many of the characteristics of impact experiments are fundamentally different from explosive loading experiments and they permit significantly different experimental arrangements which allow additional measurements to be made. A number of well-defined, precise measurements of various physical properties have now been performed with impact techniques. These measurements have demonstrated that the impact experiment is particularly well suited for the measurement of physical properties under shock-wave loading.

It is the purpose of this paper to describe several measurements of physical properties of solids under shock-wave loading as obtained with impact techniques. It is intended that these descriptions will demonstrate the unique capabilities of the impact experiment, which previous review articles concerning shock waves in solids have largely neglected.

Following a brief review of characteristics of shock waves in solids, the general features of impact experiments will be shown. The results of specific measurements of different physical properties will then be presented to illustrate the various experimental arrangements and techniques.

CHARACTERISTICS OF SHOCK WAVES IN SOLIDS

Besides the obvious differences in rates of loading and thermodynamic conditions between shock-wave loading and static high-pressure ex-

periments, one of the more basic differences is that the stress or pressure³ experienced by the sample in a shock-wave loading experiment is a direct result of the inertial response of the sample to the externally applied loading. Thus, different materials subjected to identical loading arrangements experience uniquely different pressure amplitude and pressure versus time histories which, in turn, depend upon their stress-volume behavior. Hence, it is essential to consider the interdependence of the stress-volume relation and the experimentally observable characteristics of shock waves.

Consider a plane compressive shock-wave propagating through a solid in response to a rapidly applied impulsive load at one plane boundary of the sample. The passage of the shock wave imparts a stress, σ , and a particle velocity, u , in the direction of propagation. Assuming that all stress components travel with the same shock velocity, U , the conservation of momentum relation gives

$$\sigma = \rho_0 U u \quad (1)$$

where ρ_0 is the density of the solid ahead of the front. Further, from the conservation of mass

$$V/V_0 = 1 - \frac{u}{U} \quad (2)$$

where V_0 is the specific volume ($\frac{1}{\rho_0}$) of the unstressed material and V is the specific volume of the stressed material.⁴ It is evident from equations (1) and (2) that the simultaneous measurement of values of the shock velocity, U , and

³ A plane shock wave produces a one-dimensional compression in the direction of shock propagation. Hence, while the solid offers shear resistance, the stress configuration is not hydrostatic. When the terminology "pressure" is used, it will imply that the stress configuration can be considered hydrostatic; otherwise the more precise term "stress" will be used.

⁴ Equations (1) and (2) describe a shock wave moving into an unstressed medium which is at rest. In the event multiple shock waves are propagating, the stress and particle velocity shown should be considered as the change across a particular wave front, and the shock velocity should be taken relative to the medium ahead of the front.

² Underlined numbers in parentheses designate References at the end of the paper.

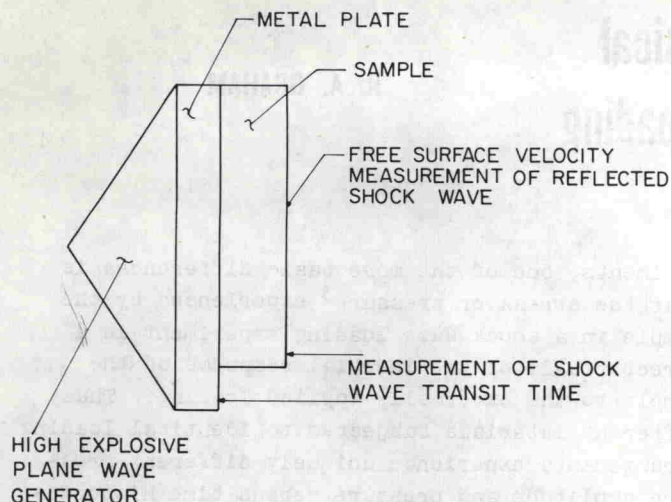

Fig. 1 Schematic drawing of a direct-contact explosive loading experiment to determine compressibility

the particle velocity, u , characterizes the stress and volume of the material under shock-wave compression, and shock-wave compressibility experiments are directed toward their determination.

A schematic diagram of a conventional shock-wave experiment to measure the compressibility of solids with explosive loading is shown in Fig. 1. A plane shock wave is produced by the detonation of a high-explosive plane-wave lens. This shock-wave is transmitted through a metal plate (typically aluminum) into the sample. Measurement of the transit time of the shock-wave through a known thickness of the sample allows the shock velocity, U , to be computed. After the shock wave traverses the sample, it impinges upon and reflects from a plane parallel surface (called the free surface), causing this surface to move with a velocity which, to a very close approximation, is equal to twice the particle velocity of the incident wave. The measurement of the free-surface velocity is accomplished by various optical and electronic techniques (7,8) and is more difficult and less precise than the shock velocity measurement. There are numerous variants of this experimental arrangement, but all are directed toward shock-wave velocity and free-surface velocity measurements.

When it is desired to measure the change in some physical property other than compressibility, resulting from the shock-wave compression, the experimental arrangement of Fig. 1 has some shortcomings. Whereas the end result desired in compressibility measurements in the U versus u data, other physical property experiments require the U, u data as the independent variable to specify the stress and volume for which physical change is measured. Large unacceptable uncertainties

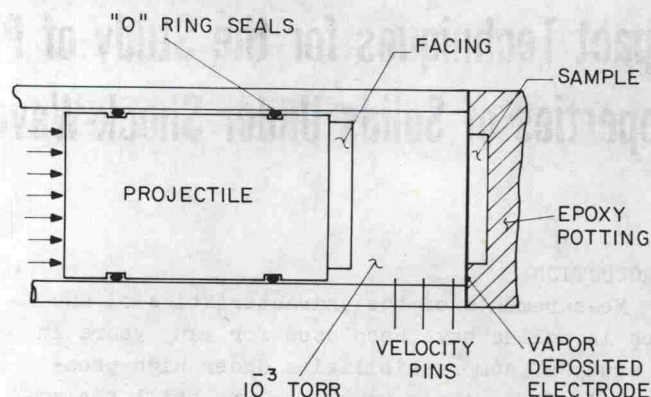

Fig. 2 Typical arrangement of an impact experiment

often result if nominal values are assumed for U and u . Further, it is difficult to arrange precise simultaneous measurements of U, u in addition to the physical property change. On the other hand, impact experiments seem to have particularly advantageous features for the measurement of physical properties under shock-wave loading.

GENERAL FEATURES OF IMPACT EXPERIMENTS

The impact experiment is conceptually simple but requires that certain exacting experimental conditions be satisfied in order to perform a satisfactory experiment. The principle features of an impact experiment are illustrated in Fig. 2.

The impact of the precisely aligned plane surfaces of two disks is produced by accelerating the impacting disk to various velocities in a smooth-bore gun. Perhaps the most convenient and effective method for accelerating the projectile is compressed gas (9-13), although propellants (14,15,16) also have been employed. The impacting disk is normally attached as a facing on the main body of the projectile. To achieve the precise alignment required, the specimen is attached to the muzzle of the gun such that the impact occurs while the projectile is guided by the accurately machined gun bore.

The allowable values for the angular misalignment between the impacting surfaces (called "tilt") vary with the nature of the experiment and the impact velocity. It is necessary for the impacting surfaces to close in times short compared to the time for the shock wave to traverse the sample. Thus, experiments at low-impact velocities require smaller values of tilt than experiments at high-impact velocity, and the techniques employed for alignment are designed to give acceptable values for tilt at low-impact velocities. Generally, an average value for tilt